



# BLAGDON

## B50 & X50

### AIR OPERATED DOUBLE DIAPHRAGM PUMP

Full Flow 2:1 Stainless Steel Series

B50

DIMENSIONS

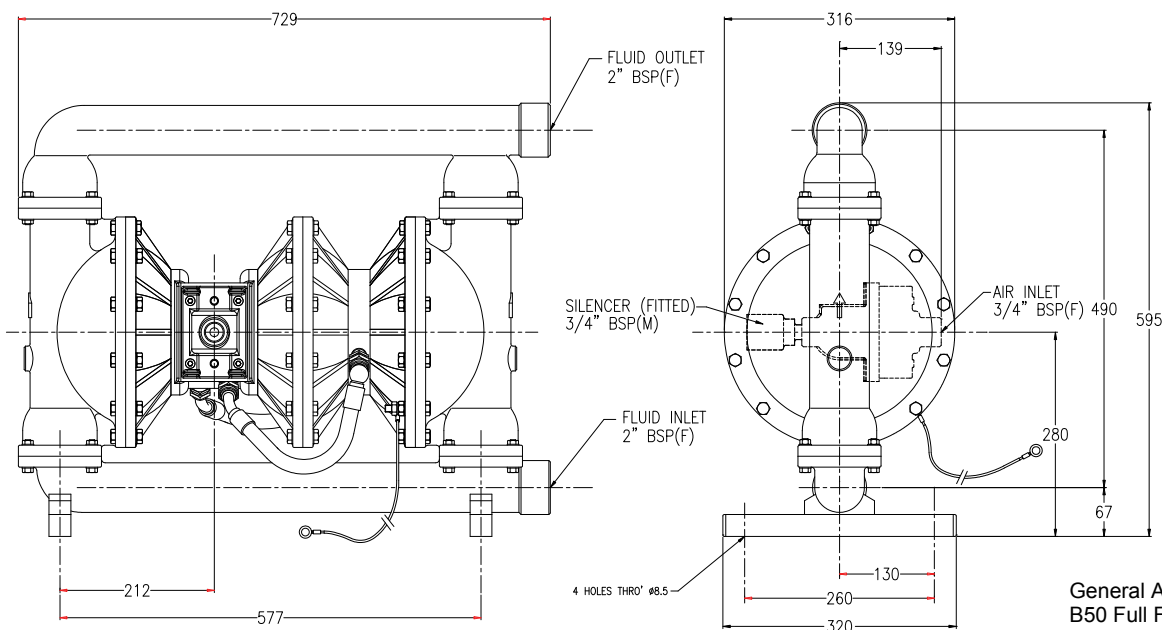

General Assembly :-  
B50 Full Flow 2:1 Pump  
All dimensions +/- 3mm

B50

PERFORMANCE

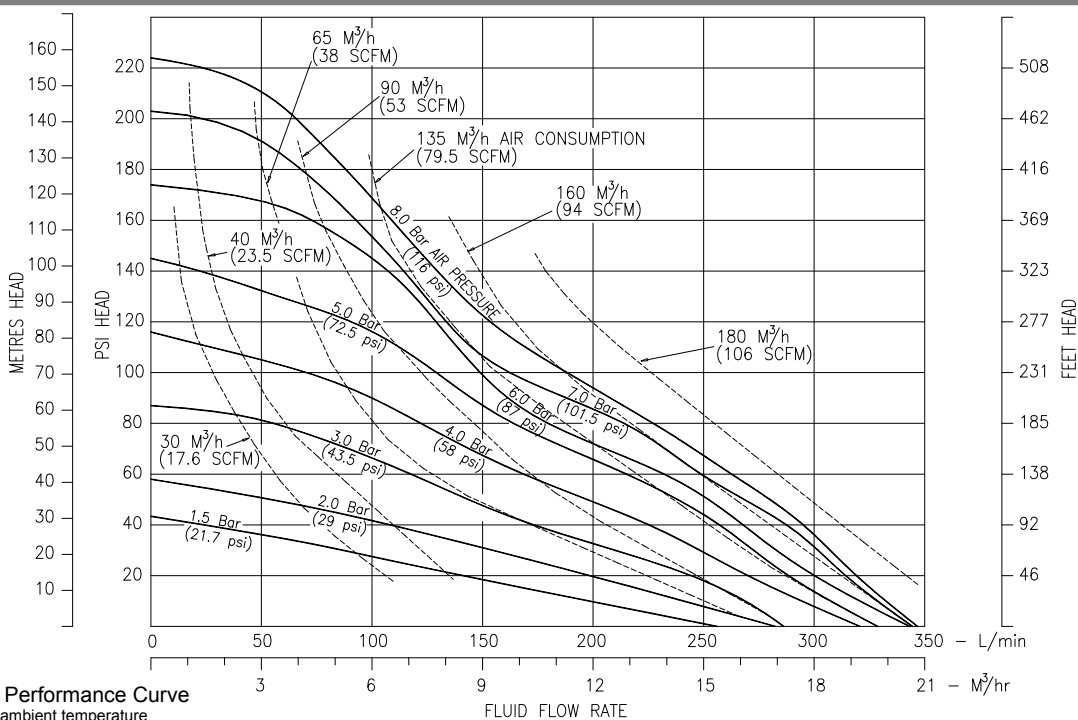

B50 Full Flow 2:1 Pump Performance Curve  
Performance based on water at ambient temperature

<b>FLUID CONNECTIONS</b> 2" BSP (F)	<b>CAPACITY</b> 0 - 341 Liters/Minute (0 - 75 Gallons/Minute)	<b>MAX SOLIDS</b> 6 MM (1/4")	<b>MAX DISCHARGE HEAD</b> 163 Meters (536 ft)	<b>DISPLACEMENT/STROKE</b> 1.9 Litres (0.42 UK Gallons)
<b>MAX. WORKING PRESSURE</b> 16 Bar (232 psi)	<b>AIR INLET</b> 3/4" BSP (F)	<b>TEMPERATURE LIMITS</b> Determined by Elastomers		<b>PUMP WEIGHTS :-</b> AA :- 65.5 Kg    SA :- 75 Kg SS :- 86 Kg

**ⓘ Caution - Operating temperature limitations are as follows:**

Operating Temperatures

**Materials**

Maximum                      Minimum                      Optimum

<b>Buna-n</b> - General purpose, oil resistant. Shows good solvent, oil, water and hydraulic fluid resistance. Should not be used with highly polar solvents like acetone and MEK, ozone, chlorinated hydrocarbons and nitro hydrocarbons.	176°F 80°C	-18°F -28°C	50° to 140°F 10° to 60°C
<b>EPDM</b> - Shows very good water and chemical resistance. Has poor resistance to oils and solvents, but is fair on ketones and alcohols.	212°F 100°C	-11°F -24°C	50° to 212°F 10° to 100°C
<b>Neoprene</b> - All purpose. Resistant to vegetable oil. Generally not affected by moderate chemicals, fats greases and many oils and solvents. Generally attacked by strong oxidising acids, ketones, esters, nitro hydro carbons and chlorinated aromatic hydrocarbons.	212°F 100°C	-4°F -20°C	50° to 130°F 10° to 54°C
<b>Santoprene®</b> - Injection moulded thermoplastic elastomer with no fabric layer. Long mechanical flex life. Excellent abrasion resistance.	212°F 100°C	-10°F -23°C	50° to 212°F 10° to 100°C
<b>PTFE</b> - Chemically inert, virtually impervious. Very few chemicals are known to react chemically with PTFE : molten alkali metals, turbulent liquid or gaseous fluorine and a few fluoro-chemicals such as chlorine trifluoride or oxygen difluoride which readily liberate free fluorine at elevated temperatures.	356°F 180°C	32°F 0°C	50° to 212°F 10° to 100°C
<b>Viton®</b> - Shows good resistance to a wide range of oils and solvents : especially all aliphatic, aromatic and halogenated hydrocarbons, acids, animal and vegetable oils. Hot water or aqueous solutions(over 70°F) will attack Viton®.	356°F 180°C	0°F -18°C	75° to 212°F 24° to 100°C

**TYPICAL CODE = B50.05. S A. W3. N N S**

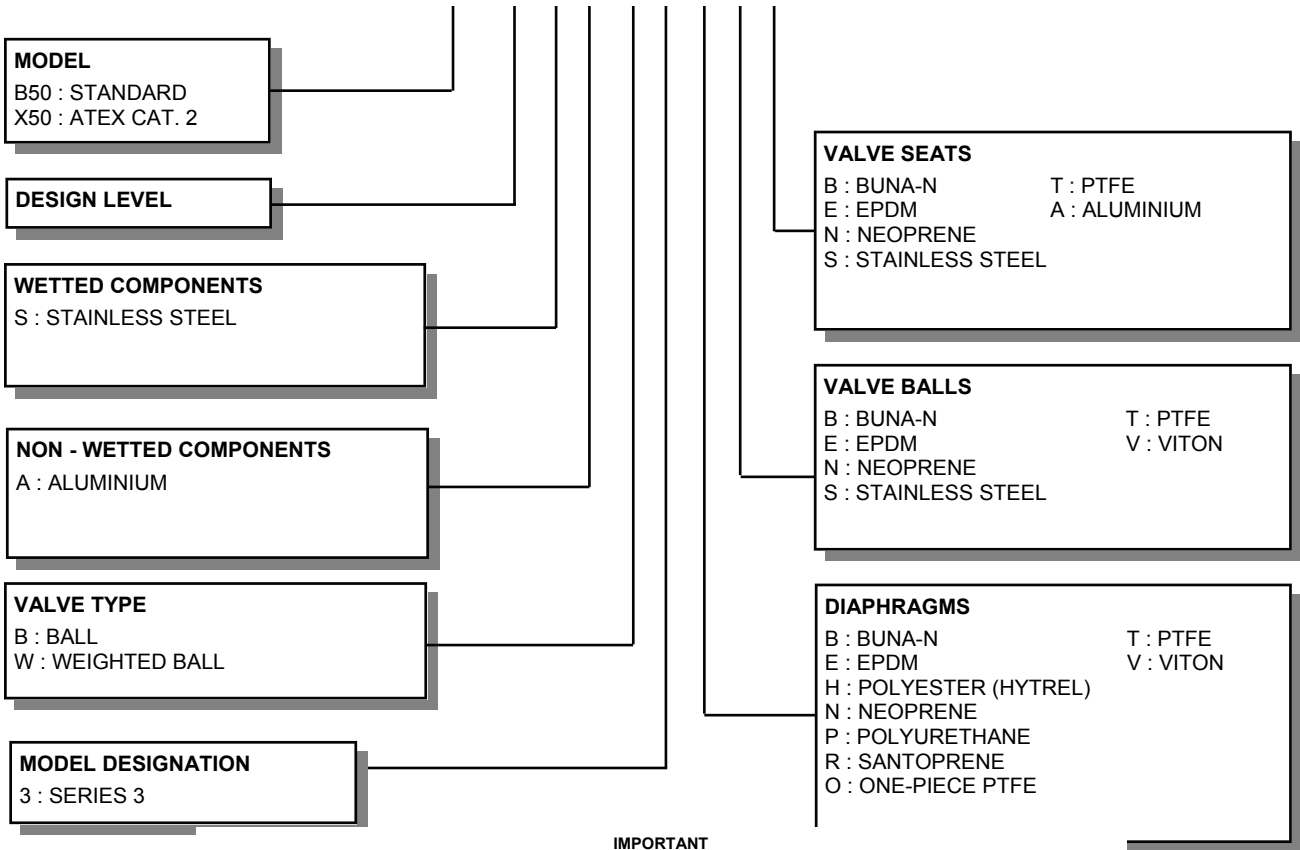

**IMPORTANT**

This pump should be used in accordance with the requirements of the Safety, Health & Welfare at Work Act 2005. All business conducted subject to IDEX Pump Technologies, Ireland. Terms and Conditions of Sale, available on request.



Pol. Ind. Aurrera, Pab. / bis - Mod. 3 48510  
TRÁPAGA (Bizkaia)  
Tel.: 944 723 104  
Fax.: 944 955 594  
rona@ronadosificacion.es